

**7 Sun Shades MK: 11SS1**  
9/53.1 A2.0 Per Window Type R

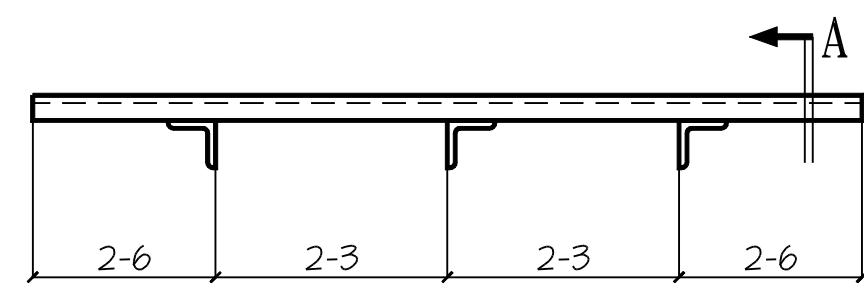

**2 Sun Shades MK: 11SS2**  
9/53.1 A2.0 Per Window Type H

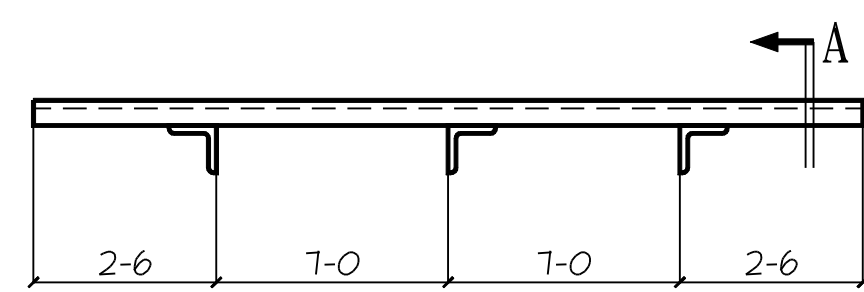

**1 Sun Shades MK: 11SS3**  
9/53.1 A2.0 Per Window Type P

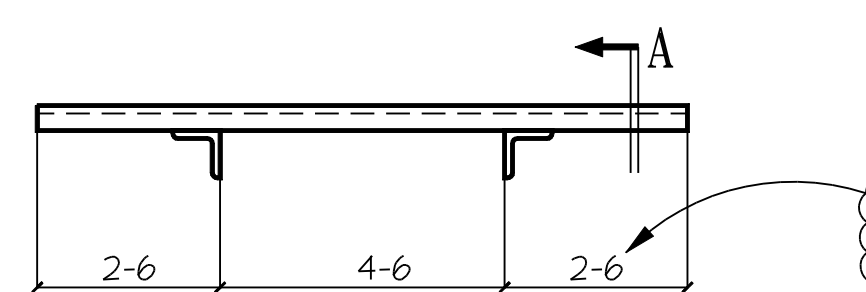

**1 Sun Shades MK: 11SS4**  
9/53.1 A2.0 Per Window Type O

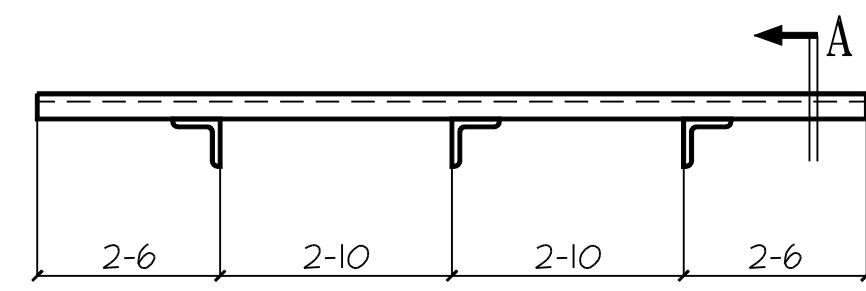

**3 Sun Shades MK: 11SS5**  
9/53.1 A2.0 Per Window Type U

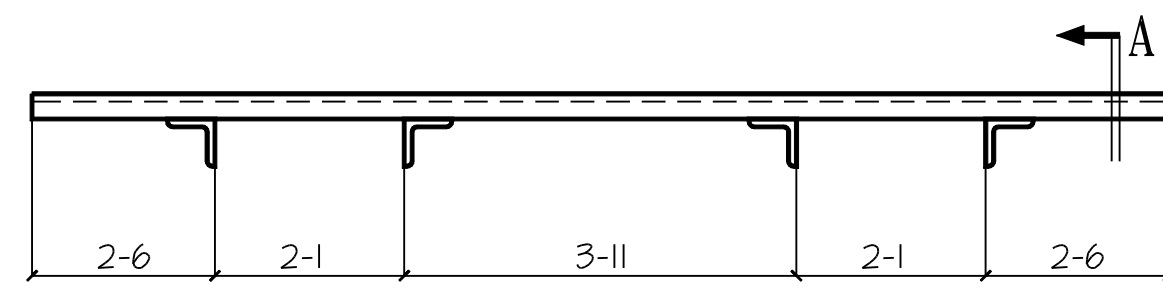

**1 Sun Shades MK: 11SS6**  
9/53.1 A2.0 Per Window Type T

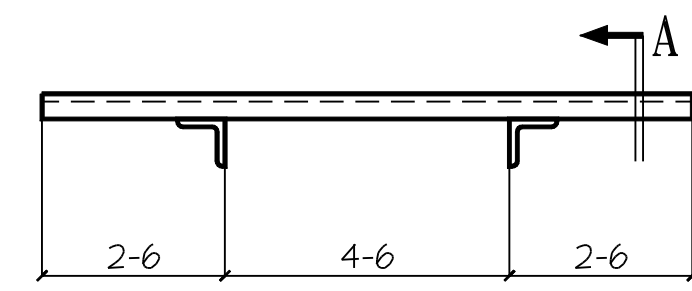

**2 Sun Shades MK: 11SS7**  
9/53.1 A2.0 Per Window Type S

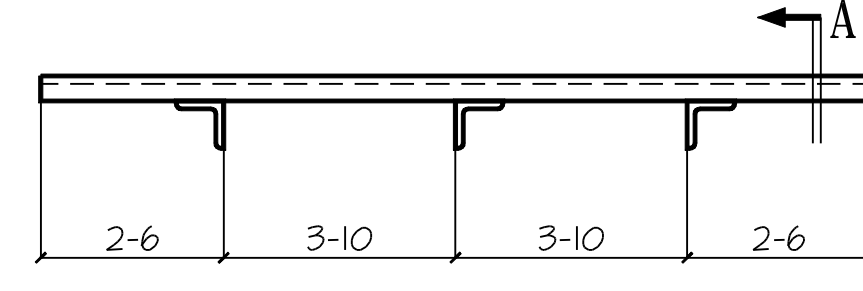

**2 Sun Shades MK: 11SS8**  
9/53.1 A2.0 Per Window Type I

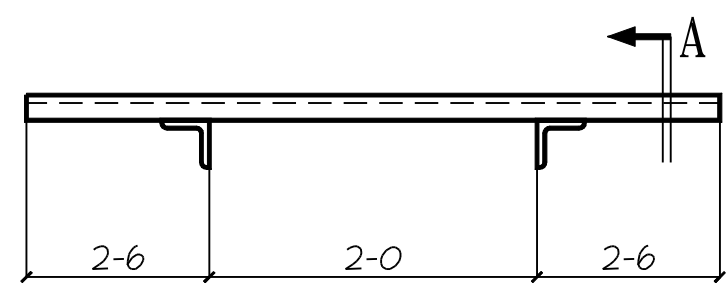

**1 Sun Shades MK: 11SS9**  
9/53.1 A2.0 Per Window Type K

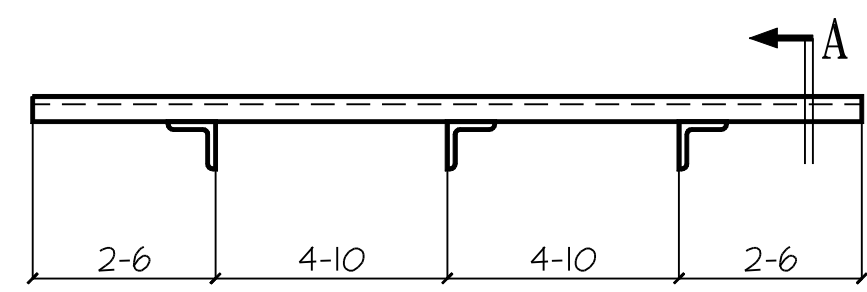

**1 Sun Shades MK: 11SS10**  
9/53.1 A2.0 Per Window Type M

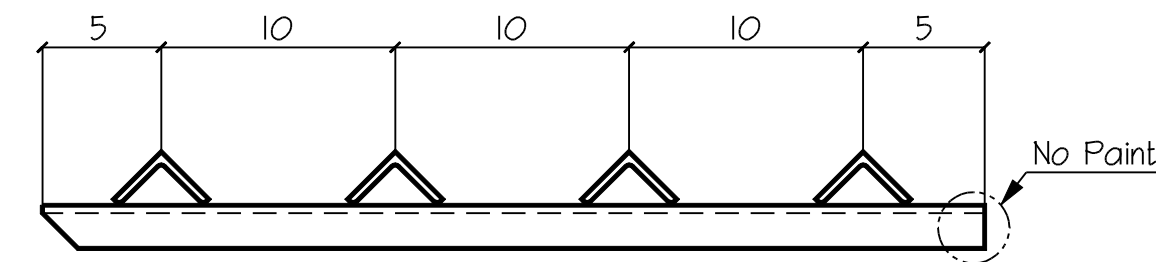

**Section A**

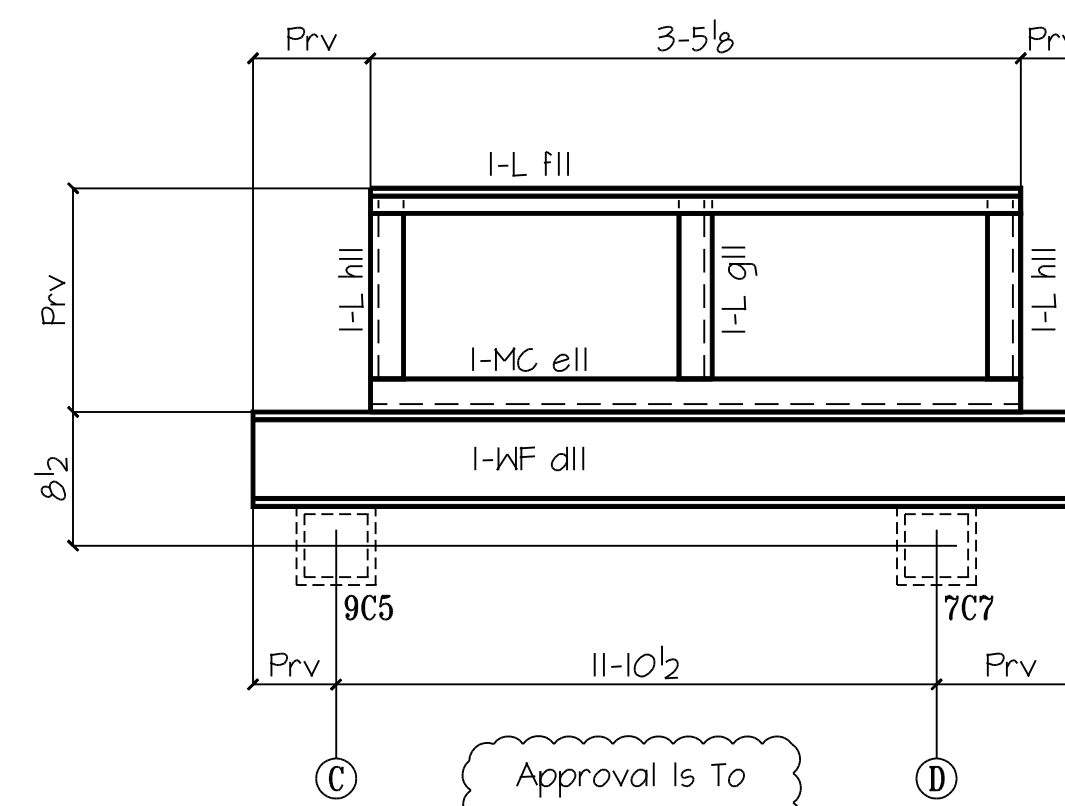

**3 Sun Canopy MK: 11SC1**  
Ref 7/53.1

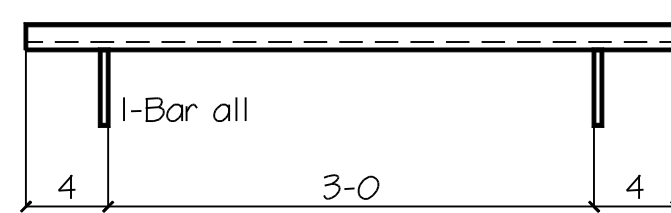

**7 Shades Brackets MK: 11SB1**  
Per Sun Shades 11SS1

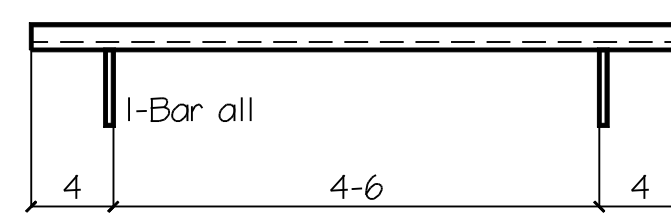

**5 Shades Brackets MK: 11SB2**  
Per Sun Shades 11SS2, 4 & 7

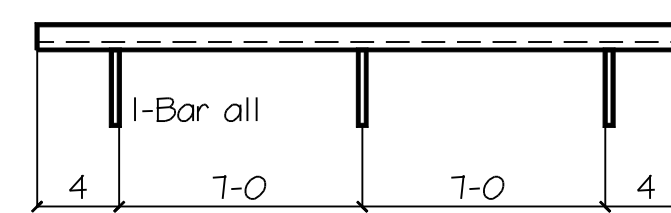

**1 Shades Brackets MK: 11SB3**  
Per Sun Shades 11SS3

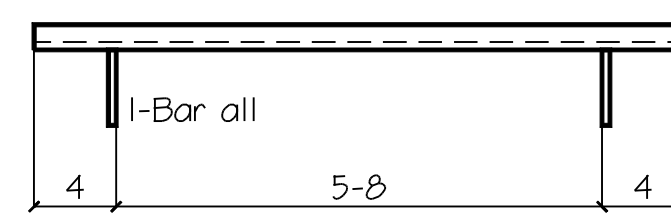

**3 Shades Brackets MK: 11SB4**  
Per Sun Shades 11SS5

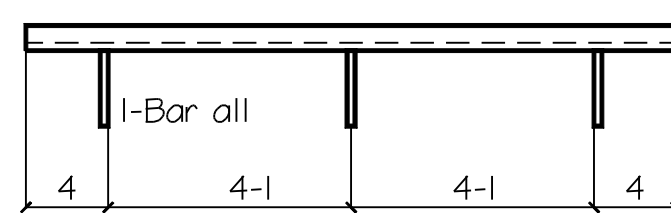

**1 Shades Brackets MK: 11SB5**  
Per Sun Shades 11SS6

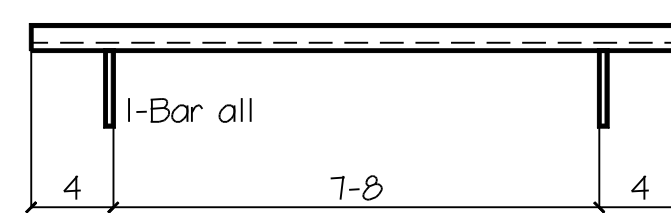

**2 Shades Brackets MK: 11SB6**  
Per Sun Shades 11SS8

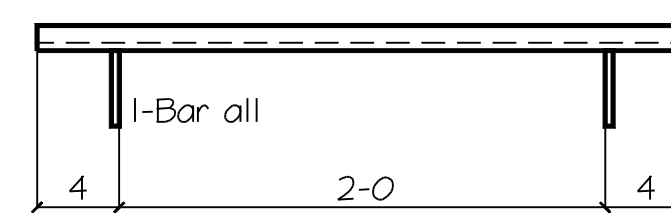

**1 Shades Brackets MK: 11SB7**  
Per Sun Shades 11SS9

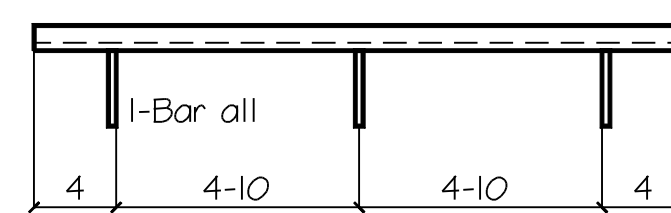

**1 Shades Brackets MK: 11SB8**  
Per Sun Shades 11SS10

- BILL OF MATERIAL -						INSPECTION	
SHIP MK	TEMP MK	QTY	DESCRIPTION	LENGTH	REMARKS	WELDER	FINALE
11551		7	Sun Shade				
	sal	28	L 3 x 3 x 1/4	8-0			
11552		2	Sun Shade				
	sbl	8	L 3 x 3 x 1/4	9-6			
11553		1	Sun Shade				
	scl	4	L 3 x 3 x 1/4	19-0			
11554		1	Sun Shade				
	sdll	4	L 3 x 3 x 1/4	9-6			
11555		3	Sun Shade				
	sell	12	L 3 x 3 x 1/4	8-8			
11556		1	Sun Shade				
	sdll	4	L 3 x 3 x 1/4	13-1			
11557		2	Sun Shade				
	sell	8	L 3 x 3 x 1/4	9-6			
11558		2	Sun Shade				
	sfll	8	L 3 x 3 x 1/4	12-8			
11559		1	Sun Shade				
	sgll	4	L 3 x 3 x 1/4	7-0			
115510		1	Sun Shade				
	shll	4	L 3 x 3 x 1/4	14-8			
	ssll	58	L 3 x 3 x 1/4	3-4	Per Sun Shade		
115C1		1	Sun Canopy		Ref 7/53.1		
	dll	1	W6x15	Prv			
	ell	1	MC12x10.6	Prv			
	fill	1	L 1 1/2 x 1 1/2 x 1/4	Prv			
	gll	1	L 3 x 3 x 1/4	Prv			
	hll	2	L 3 x 3 x 1/4	Prv			
115B1		7	MC12x10.6	3-8			
115B2		5	MC12x10.6	5-2			
115B3		1	MC12x10.6	14-8			
115B4		3	MC12x10.6	6-4			
115B5		1	MC12x10.6	8-10			
115B6		2	MC12x10.6	8-4			
115B7		1	MC12x10.6	2-8			
115B8		1	MC12x10.6	10-4			
	all	34	Bar 1/4 x 6	1-0	Per Brackets		

Useable Template Mark Letters  
# c d e l g h j k m n p q r s t v w y z  
TSD File: DaySpa\_misc.dwg

- DESCRIPTION OF REVISIONS MADE TO DRAWING -				
1				
2				
3				
	REVISION DESCRIPTION	DATE	MADE BY	CHK BY
	REF DWG E5 & S2.2			

MATERIAL GRADE SHELL BE <u>A36</u> U.N.O.	DETAILS OF Sun Shades
WF SHAPES <u>A992</u> TUBES <u>A500</u>	CUSTOMER
CHANNELS <u>A992</u> PIPES <u>A501 or A53</u>	ARCHITECT
COATING <u>One S/C Red Oxide Primer</u>	PROJECT <u>Whispering Waters Day Spa</u>
	LOCATION
<u>13/16"</u> OPEN HOLE	<u>1/4"</u> FILLETS
<u>E700XX</u> ELECTRODES	
APPROVAL _____ TO SHOP _____	DETAIL <u>DY</u> <u>4-16-08</u>
	CHK.R _____
	JOB # <u>8007</u>
	SHEET # <u>D11</u>

